

SWING DOOR DRIVE UNIT

GILGEN FD 10



Compact and reliable drive mechanism for use in areas with heavy footfall. This low-noise electromechanical drive unit comes in an impressively sleek package. Its design is both robust and vandal-resistant, making it suitable for any location.

- Compatible with single/two-leaf doors and interlock accesses
- Controlled, spring-actuated closure with motor assistance
- The drive mechanism has a built-in travel stop
- Freely selectable Full Power and Low Energy functions in a single drive mechanism
- Assisted-opening option, with servo function
- Terminals for connecting accessories such as locks, security/safety elements or operating controls
- Voltage-free outputs for acknowledgements to, for example, the building management system (via relay PCB)
- Simple to set up and operate via the integrated graphic display screen
- TÜV approved and complies with the pertinent standards and requirements (e.g. EN 16005, DIN 18650)

Range of application

Max. door leaf weight	150 kg
Door sizes single leaf	730 – 1100mm
Door sizes two-leaf	1460 – 2200mm
Max. opening angle	105°

Dimensions of drive system

Height	70 mm
Width	730 mm
Depth	125 mm

Possible applications

Standard rods with pushing function
Lintel installation

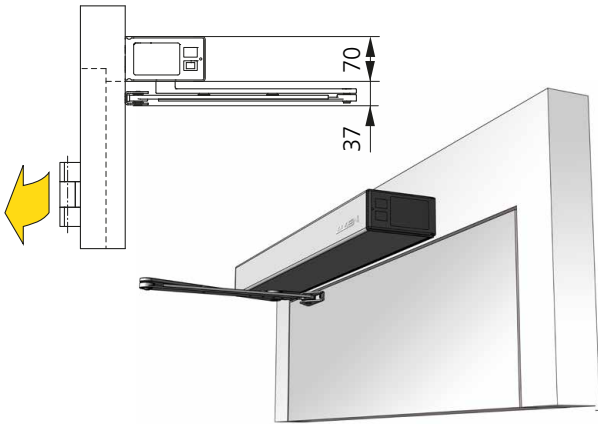

Standard rods with pushing function
Door leaf installation

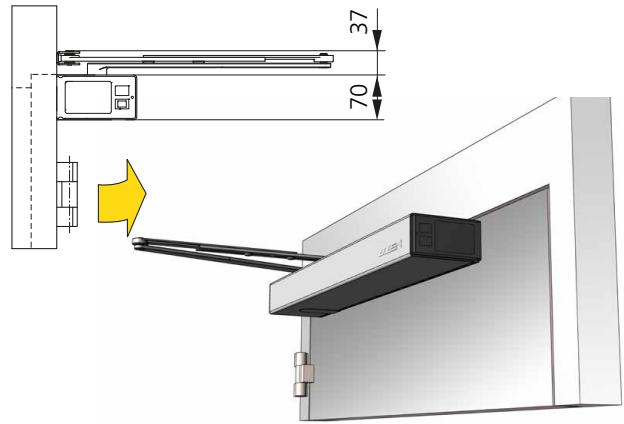

Sliding rods with pushing function
Lintel installation

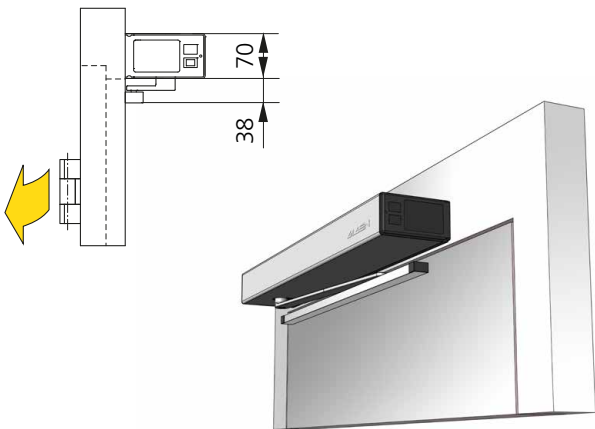

Sliding rods with pushing function
Door leaf installation

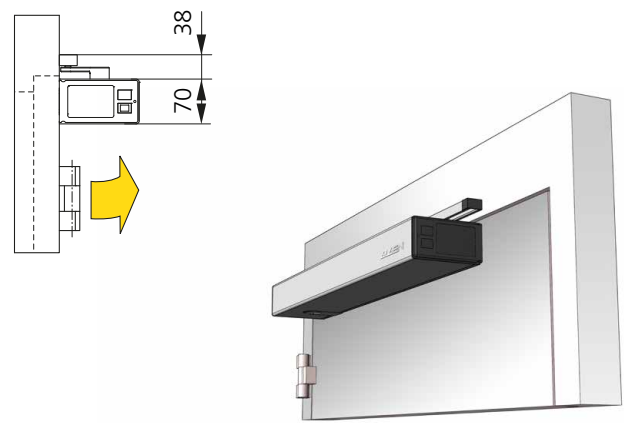

Sliding rods with pulling function
Lintel installation

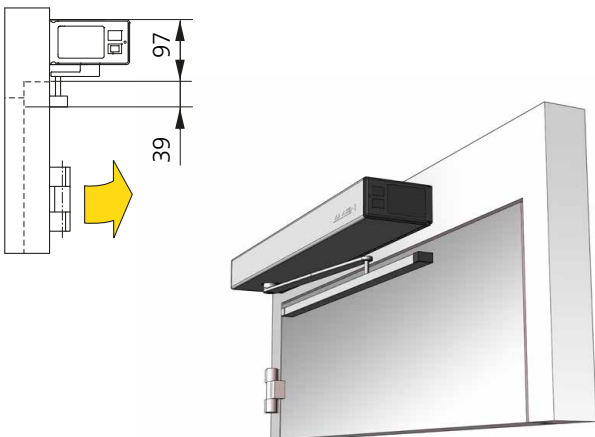

Sliding rods with pulling function
Door leaf installation

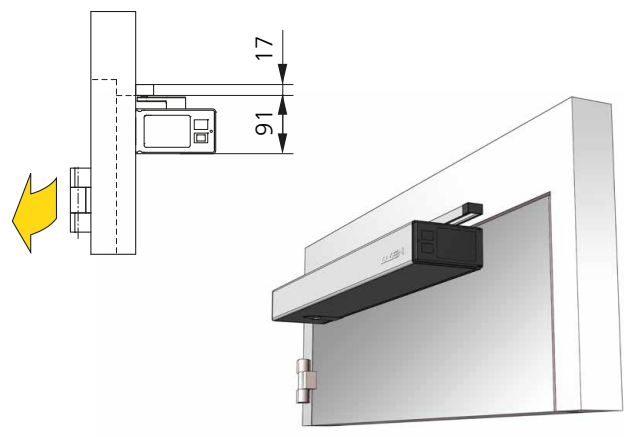

Technical data

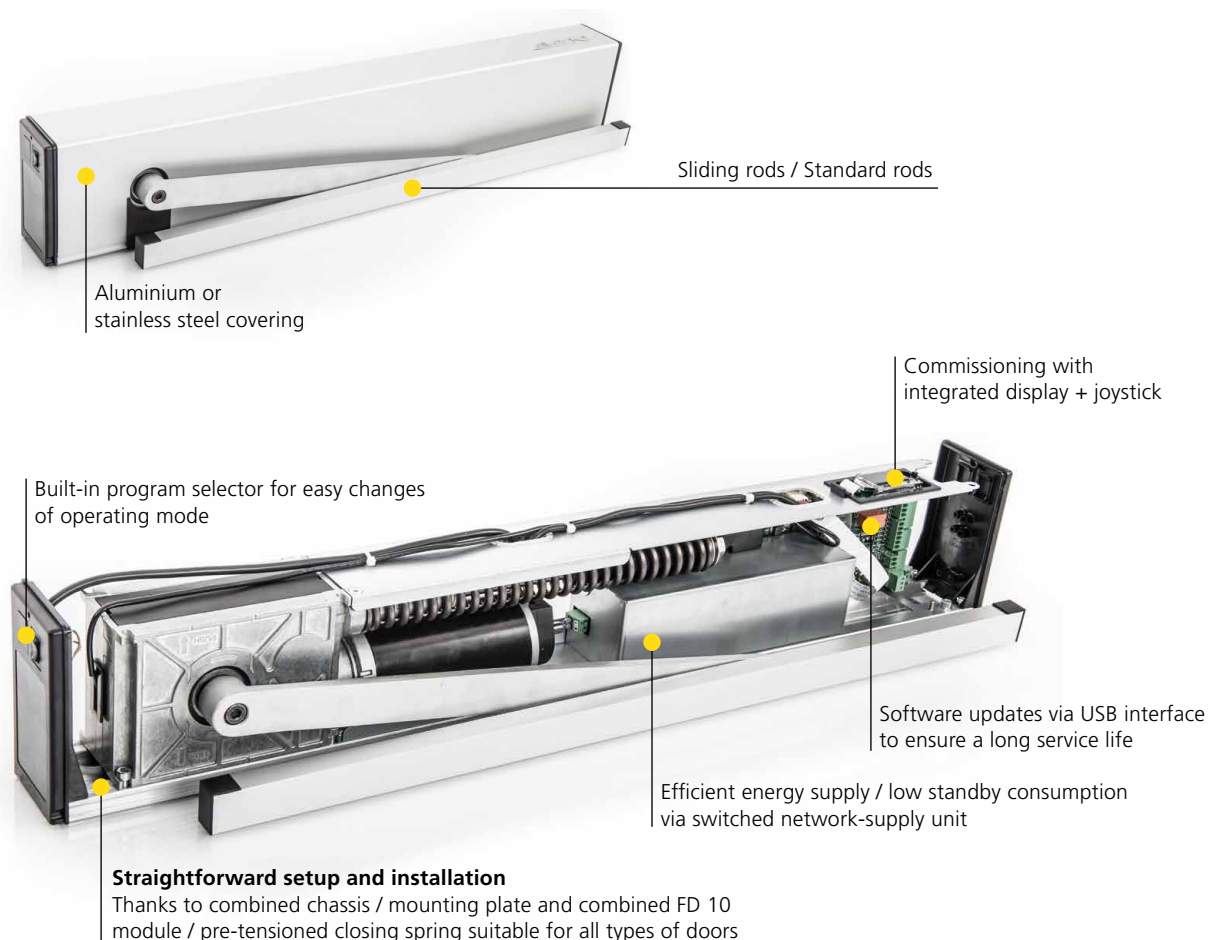

Power transfer	Standard rods (pushing function) Sliding rods (pushing and pulling function)
Weight of drive system	8.2kg
Protection rating	IP 20
Ambient temperature	-15 to +50 °C
Operating voltage	230 VAC (+10/-15 %), 50 Hz, 10/13 A
Power consumption of drive system	maxx 350 W
Rated motor capacity	100 W
Stand-by consumption	4 W
Power supply, external user	24 VDC (±10 %), 1,4 A
Lintel depth standard rods	max. 250 mm
Lintel depth sliding rods	-50 / +150 mm
Opening speed	max. 40°/s
Closing speed	max. 40°/s
Relative humidity	max. 85 %
Output shaft torque	permanent max. 56 Nm short max. 165 Nm